

HQ AFSVA/SVPAR
Annual Standardization Exam

1 May 2009

(supplement with 15 local area questions)

(Required passing score: 80%)

Please do not mark on booklet

Annual Standardization Exam Questions (35)

(Select **Best Answer** for each question)

(Question 1 through 10 references AFMAN 34-232)

1. You have a Private, SEL rating with 250 hours and a current FAA Medical. You last flew an Aero Club Archer on 15 Aug, and accomplished 3 takeoffs and landings. You last flew an Aero Club Cessna 172 on 15 Oct. On that flight you accomplished 3 takeoffs and landings. It is 1 December and prior to flying as PIC of an Aero Club Piper Archer you must accomplish the following (All dates are in same calendar year):
 - A. recurrency check and closed book exam for that make and model aircraft.
 - B. Three takeoffs and landings to with a current and qualified club certified flight instructor (CFI).
 - C. Nothing, you are current to fly the Archer.

2. No person shall operate or occupy a club aircraft unless they have _____ within the previous 12 months. (NOTE: This requirement does not apply to FAA Inspectors performing official flight examinations.)
 - A. successfully completed the applicable checkout requirements
 - B. executed an AF Form 1585, Covenant Not to Sue and Indemnity Agreement
 - C. has been endorsed by a flight instructor for solo flight

3. Who is personally responsible for the safety and actions of passengers?
 - A. The PIC
 - B. Each passenger, after a proper safety briefing by the PIC
 - C. Each passenger, regardless of receiving a briefing by the PIC

4. The PIC:
 - A. shall ensure appropriate survival and safety equipment for the intended operation area is onboard the aircraft.
 - B. shall ensure an FAA approved personal flotation device for each occupant is onboard the aircraft and readily accessible on all flights.
 - C. shall ensure adequate tie-down equipment is onboard for all flights.

5. Managers shall supply a consolidated aircraft checklist for each aircraft operated. Use of the checklist by pilots is
 - A. mandatory.
 - B. optional.
 - C. highly encouraged.

6. Use of locally developed in-flight guides is
 - A. mandatory.
 - B. optional.
 - C. highly encouraged

7. Pilot Currency. Managers or Chief Flight Instructors _____ credit pilot activities performed in other than club aircraft to satisfy currency requirements.
 - A. Will not
 - B. Should not
 - C. May

8. Simulated emergency training
 - A. may be conducted in Instrument Meteorological Conditions (IMC) with approval from the club manager or Chief Flight Instructor
 - B. is limited to Visual Meteorological Conditions (VMC)
 - C. is not authorized in any Aero Club aircraft, unless part of the private pilot syllabus.

9. The following shall not be performed at night.
 - A. VFR Flight below 2,000 feet AGL for any/every stage of flight
 - B. Operations at airports without runway lighting
 - C. Unusual attitudes, stalls, approach to stalls, or flight at minimum controllable airspeed, when required by Part 141 approved syllabus instruction

10. Which of the following statements regarding flight plans is false?
 - A. Pilots shall file a flight plan for all flights outside the local area.
 - B. Before filing to a military field, contact the destination base operations and aero club (if applicable) to ensure they can accept the aircraft, and obtain a Prior Permission Required (PPR) number, if required. (**NOTE:** Enter the statement "USAF Aero Club aircraft, please advise _____ Base Operations" in the remarks section of the flight plan.)
 - C. When departing a military base from other than home station, the pilot is not required to file a flight plan with the local base operations.

(Question 11 references NTSB Part 830)

11. An aircraft accident is an occurrence associated with the operation of an aircraft which takes place _____, and in which any person suffers death or serious injury, or in which the aircraft receives substantial damage.
 - A. between the time any person boards the aircraft with the intention of flight and all such persons have disembarked
 - B. between the time any person sets the power with intention of takeoff and the aircraft comes to a complete stop after final landing
 - C. between the time the aircraft first begins movement after first engine start and the aircraft makes a final stop prior to final engine shutdown

(Questions 12 through 17 reference 14 CFR Part 91)

12. When can a pilot in command of an aircraft deviate from any rule under FAR part 91?
 - A. during an in-flight emergency requiring immediate action, the pilot can deviate from all sections of part 61
 - B. in order to comply with ATC direction while operating at a military airfield
 - C. during an in-flight emergency requiring immediate actions, to the extent required to meet that emergency

13. Who is responsible for determining whether an aircraft is in condition for safe flight?
 - A. the aero club manager
 - B. the pilot in command of the aircraft
 - C. a certificated aircraft maintenance inspector

14. An aircraft's operating limitations may be found in the
- A. FAA-approved aircraft flight manual.
 - B. owner's handbook published by the aircraft manufacturer.
 - C. aircraft flight manual, approved manual material, markings, and placards, or any combination thereof.
15. While on base leg in an airport traffic pattern, you sight another airplane on final. The airplane that has the right-of-way is the one
- A. that is the least maneuverable
 - B. which is closest to the landing threshold
 - C. on final approach, regardless of altitude
16. You are approaching to land at an airport and see an alternating red and green light signal. You should
- A. Exercise extreme caution
 - B. Give way to other aircraft and continue circling
 - C. not land because the airport is unsafe
17. Special VFR may only be conducted
- A. Clear of Clouds
 - B. in a multi-engine aircraft
 - C. if the PIC has a Special VFR endorsement

(Questions 18 through 20 reference 14 CFR Part 61)

18. The holder of a pilot certificate who has made a change in permanent mailing address may not, after _____ from that date, exercise the privileges of the certificate unless the holder has notified the FAA of the new permanent address.
- A. 30 days
 - B. 60 days
 - C. 90 days
19. A student pilot may act as the pilot in command of an aircraft carrying passengers, provided the instructor has endorsed the student pilot certificate for solo flight.
- A. True
 - B. False
20. In relation to operating expenses while you are acting as pilot in command, the regulations specify that as a private pilot you may
- A. not share operating expenses with passengers
 - B. share the operating expenses with passengers
 - C. share the operating expenses with passengers and receive compensation from them for pilot services

(Questions 21 and 22 reference FAA-H-8083-3A)

21. Which of the following is required to spin an aircraft??
- A. Stalled wing
 - B. High rate of rotation
 - C. Rapid loss of altitude

22. (Refer to figure 1.) In flying the rectangular course, when would the aircraft be turned less than 90 degrees?
- A. Corners 1 and 4
 - B. Corners 1 and 2
 - C. Corners 2 and 4

(Questions 23 through 27 reference FAA-H-8083-25A)

23. If a pitot tube is blocked, which instrument would be affected?
- A. Altimeter
 - B. Airspeed Indicator
 - C. Vertical speed indicator
24. On a standard airspeed indicator, the bottom of the white arc indicates?
- A. The lowest speed at which the airspeed indicator is calibrated for normal use
 - B. The stalling speed, or the minimum steady flight speed in the landing configuration
 - C. The maximum speed with the flaps extended

25. On a cross-country flight, point A is crossed at 1500 hours, and the plan is to reach point B at 1530 hours. Use the following information to determine the indicated airspeed required to reach point B on schedule.

Distance between A and B.....70 NM
 Forecast wind.....310° at 15 kts
 Pressure altitude.....8000 ft
 Ambient temperature.....-10°C
 True course.....270°

The required indicated airspeed would be approximately

- A. 126 knots
 - B. 137 knots
 - C. 152 knots
26. (Refer to figure 2.) An aircraft operated at an airspeed indicated by point B represents?
- A. The most fuel efficient airspeed
 - B. The minimum controllable airspeed
 - C. The minimum total drag airspeed
27. The standard weight for gasoline is?
- A. 6.8 lb/US gal
 - B. 6.0 lb/US gal
 - C. 8.35 lb/US gal

(Questions 28 through 32 reference AIM)

28. (Refer to figure 4.) Where does Class E airspace begin over McCampbell Airport (area 1)?
- A. Surface
 - B. 717 feet AGL
 - C. 1,217 feet MSL

29. (Refer to figure 4.) While on a flight from Alice Airport (area 7) to McCampbell Airport (area 1) at 5,500 feet MSL, when, if ever, is a transponder required?
- A. Transponder is not required
 - B. Required when overflying the Corpus Christi Class C Airspace
 - C. Required when leaving and entering the alert areas and overflying the Corpus Christi Class C airspace
30. How does the wake turbulence vortex circulate around each wingtip?
- A. Inward, upward and around each tip
 - B. Inward, upward and counterclockwise
 - C. Outward, upward and around each tip
31. Normally, the vertical limits of Class D airspace extend up to and including how many feet above the surface?
- A. 2,500 feet
 - B. 3,000 feet
 - C. 4,000 feet
32. Except when requested by the controller or in emergency situations, _____ should never be executed in the traffic pattern or when receiving radar service without first advising the controller.
- A. lowering of flaps
 - B. slowing to pattern or approach speed
 - C. a 360 degree turn

(Questions 33 through 35 reference AC 00-6A)

33. An unstable air mass is characterized by?
- A. Poor visibility and smooth air
 - B. Cumuliform clouds and shower precipitation
 - C. Stratiform clouds and continuous precipitation
34. Which is an operational consideration regarding aircraft structural icing?
- A. It is unnecessary for an aircraft to fly through rain or cloud droplets for structural ice to form
 - B. Clear ice is most likely to form on an airplane when flying through stratified clouds or light drizzle
 - C. In order for structural ice to form, the temperature at the point where moisture strikes the aircraft must be 0°C (32°F) or colder
35. Which condition could be expected if a strong temperature inversion exists near the surface?
- A. Strong, steady downdrafts and an increase in OAT
 - B. A wind shear with the possibility of a sudden change of airspeed
 - C. An OAT increase or decrease with a constant wind condition

Local Area Questions:

Refer to the LeMay Flight Training Center Standard Operating Procedures (SOPs) to answer the following 15 questions.

36. All pilots, to include student pilots and all others receiving instruction, must read all current and applicable Pilot Information File (PIF) information.
 - a) True.
 - b) False.
37. All aircraft are scheduled on a "first come, first served" basis, however, FAA check flights have priority.
 - a) True.
 - b) False
38. When landing at Offutt, the preferred runway exit point for LFTC aircraft is _____ unless tower directs otherwise.
 - a) Taxiway "Mike"
 - b) The first available taxiway from either runway.
 - c) Taxiway "Mike" when using Runway 12, Taxiway "November" when using Runway 30.
 - d) Taxiway "November".
39. Before taxiing behind a jet aircraft parked on any Offutt ramp, the PIC must
 - a) Ascertain that the jet's engines are not running or appear to be at idle thrust before proceeding.
 - b) Verify with "Offutt Ground" that the jet's engines are not running before proceeding, then ask Ground Control to move the jet if the engines are running.
 - c) Verify that the jet is more than 50 feet away before proceeding.
40. Aero club members who are current in the airplane may practice simulated forced landings without an instructor accompanying them.
 - a) True.
 - b) False.
41. Touch-and-Go landings are permitted in LFTC aircraft _____.
 - a) Flown by solo students.
 - b) With retractable landing gear.
 - c) Only by rated pilots in fixed gear aircraft.
42. All aircraft departing overnight for overnight or cross-country flights will be fueled _____ prior to departing Offutt AFB.
 - a) With enough fuel to reach the destination.
 - b) With enough fuel to reach the destination plus one hour reserve.
 - c) To the maximum fuel quantity allowed based on a weight and balance computation.
 - d) None of the above are true.

43. If you are on a cross-country flight and have a maintenance problem you should _____.
- a) Continue to destination.
 - b) Attempt to repair the problem yourself.
 - c) Authorize a qualified mechanic to repair it.
 - d) Contact the LeMay Aero Club regarding aircraft maintenance problems.
44. If you are out flying and crosswinds at Offutt AFB become a problem, the *designated* crosswind alternates are Plattsmouth, Council Bluffs, _____ & _____.
- a) Wahoo & Shenandoah.
 - b) Millard & North Omaha.
 - c) Weeping Water & Nebraska City.
 - d) None of the above.
45. LeMay Aero Club aircraft may be landed on sod (grass runway) fields _____.
- a) After being trained by a flight instructor.
 - b) After training has been logged on an AF Form 1584.
 - c) Both of the above.
 - d) None of the above.
46. During the winter months a Runway Condition Reading or RCR may be assessed by Offutt airfield management. An RCR of _____ corresponds to a braking action of "poor" or "nil" and LeMay Aero Club aircraft cannot be operated without permission of the LeMay Aero Club Manager or Chief CFI.
- a) 18 or more
 - b) 16
 - c) 14
 - d) 12 or lower
47. If you are flying in the local area and hear air traffic control for Omaha or Offutt AFB announce a "weather recall" you should expect _____.
- a) To be directed to return to base or comply with other special instructions.
 - b) No traffic conflicts in the traffic pattern.
 - c) Al-Qaida is playing a trick on us.
48. Solo student pilots may be cleared by _____.
- a) Any licensed club pilot.
 - b) Any clearing official (manager, secretary).
 - c) Any LeMay Aero Club CFI.
 - d) A LeMay Aero Club instructor familiar with their training (i.e., someone who has flown with them).

49. While practicing landings at Plattsmouth airport you are hit with a gust of wind and inadvertently stray onto the grass area. Is this incident reportable to 55 Wing Safety?
- a) Yes.
 - b) No.
50. The local flying area is _____.
- a) Within 50 miles of Offutt AFB for licensed pilots.
 - b) Within 25 miles of Offutt AFB for student pilots.
 - c) Both of the above statements are true.

Annual Standardization Exam (Test A) Figures

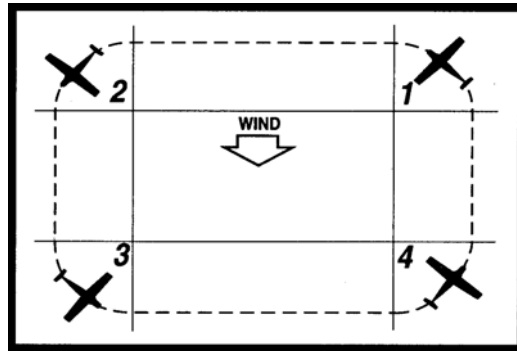

Figure 1 – Rectangular Course

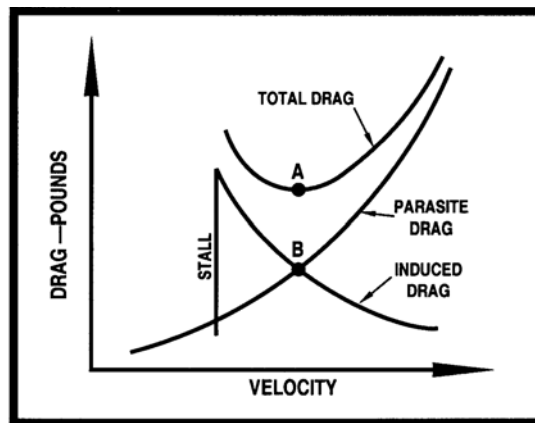

Figure 2 – Drag Chart

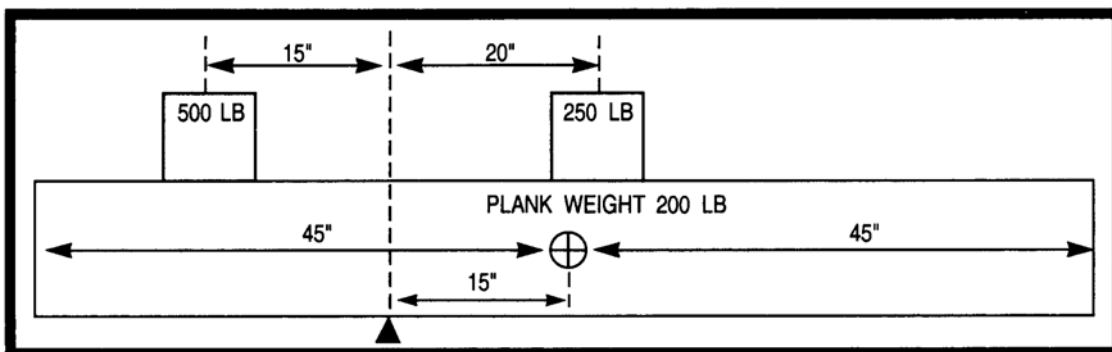

Figure 3 – Weight and Balance Diagram

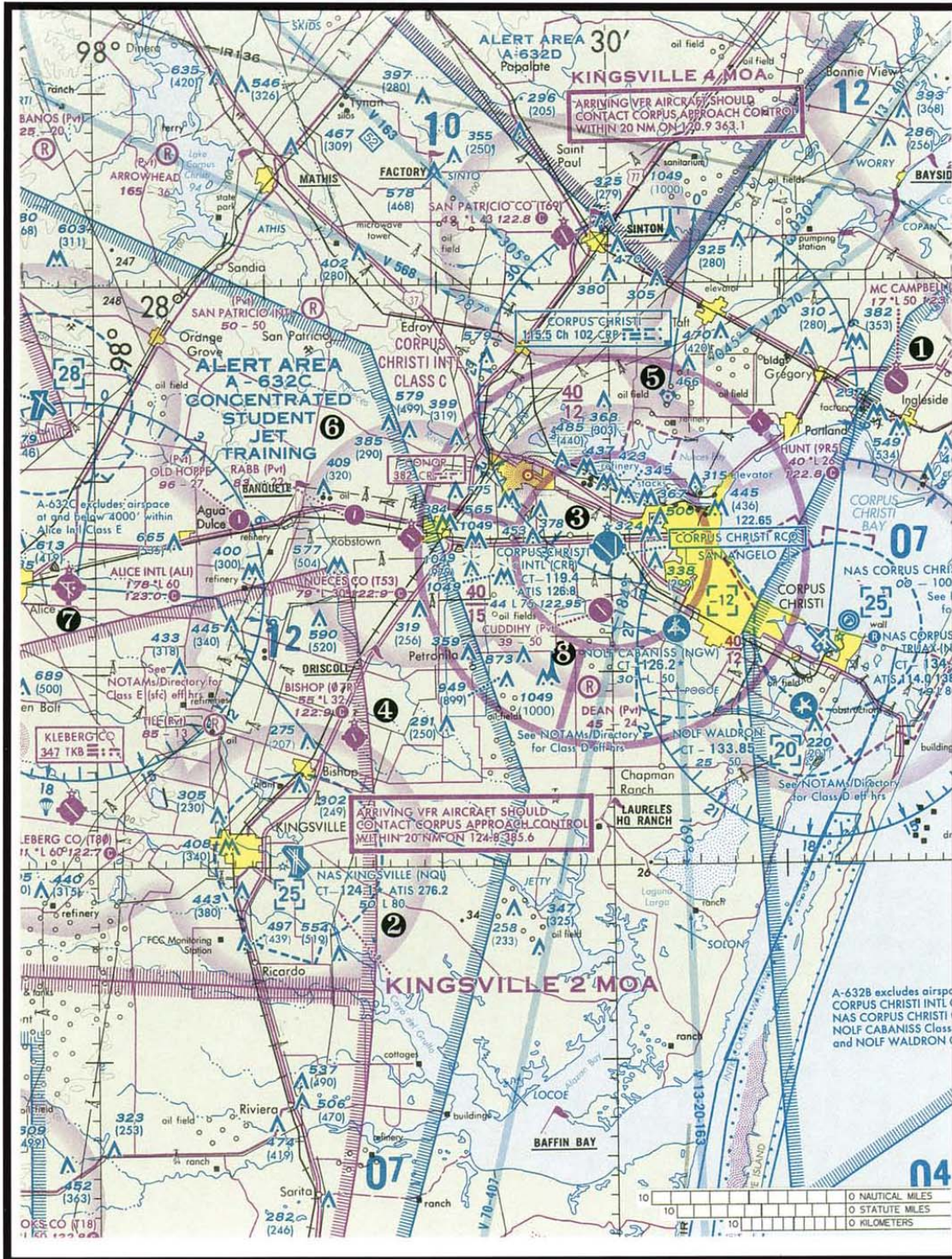

Figure 4 – Sectional Chart Excerpt